



Remote Monitoring Unit



DATA SHEET

+44 20 8895 6455
info@webbinfra.com
www.webbinfra.com



Environmental Monitoring

Webb environmental monitoring products permit you to actively monitor the conditions in BTS stations, warehouses, datacenters, colleges /educational institutes, hospitals, offices, restaurants, farmsteads, factories, museums or wherever it is essential to have a climate controlled environment. Upholding a constant & steady environment where equipment or products are housed is critical for operation, protection and usage in various industries. Conditions monitoring consist of temperature, humidity, power spikes and surges, liquid leakage, SNMP traps from other devices along with smoke & airflow.

Webb environmental monitoring equipment allows network machinists to detect conditions from a secure web interface and obtain SNMP, E-mails, and text message or siren/alert warnings when environmental sensors detect a breach in the preset thresholds. These products can also make you cognizant of the potential damages from critical failures. The Web interface can demonstrate live video surveillance and environmental magnitudes, which are logged to track patterns.

T.10.825- Remote Monitoring Unit

Features

- Middle level unit is used in computer rooms, remote & industrial facilities and offices. can use up to 100 different elements such as notifications, triggers, timers, logics, sensors & dry contacts
- There are built-in servers and agents like HTTP, HTTPS, SNMP v1, 2c, 3, SMTP, radius, syslog, FTP, DHCP & watchdog
- T.10.825 / monitoring unit authorization is going through the Radius protocols that highly increases resistance to forced attacks
- Receive warnings of irregular events via email, SMS / MMS, SNMP traps
- Integrates with network management systems via SNMP v.1 and encrypted SNMP v.3
- Uses linux operating system for maximum solidity, reliability and flexibility
- Web GUI for PC, smartphones and tablets with free firmware upgrades and utilities
- Monitor up to 30 different sensors using expansion CAN units
- Compatible with the entire range of multiple third-party sensors
- Embedded web server displays sensor information and live video from connected cameras
- Compatible with all webb sensors

**Specifications are subject to change without notice based on technical recommendations and related product enhancements*



**Specifications are subject to change without notice based on technical recommendations and related product enhancements*

Technical Specifications

Dimensions	Width 440 x height 44.45 (1U) x depth 79.4 mm
Weight	1,5 kg
Inputs	8 analog sensors, CAN bus, HS USB, 4 dry contacts (3P, pitch 3,5mm, type IN)
Operating characteristics	Humidity: minimum. 5% - maximum. 95% (non-condensing), temperature: minimum. -10° C - max.80° C
Power input	Fuse 2A, 90-240V, IEC C14
Network interface	CAN bus, 1-wire (with extension), ethernet 10/100 Mbit/s
Outputs	SD card slot, USB port for saving logs (USB flash), Two 12V 0,25A outputs (pitch 3,81mm, 3P)
Mounting	Desktop, wall turnable mount (with extension), 19" rack mountable
Expansions (ordered separately)	1-wire board" or "Extension board", GSM modem
Power consumption	12 watt
Status indicators	Two relay status LEDs, LED indication for power / network connectivity, error LED, LED indication for CAN bus connection
Components	Manufactured in E.U
Max. distance	300 m
HS code	8471 50 000
Processor	ARM926-300 MHz / 64 MB / linux-2.6.38
Built-in sensors	Power supply voltage sensor (1%), temperature sensor (1%)
Package inclusions	Warranty card,short description and connection guide,terminal plug 6 pins 3.5 mm1pcs, terminal plug 3 pins 3.81mm 1pcs,self-adhesive rubber foot 4 pcs,patch cable RJ-45 1m, cable EU schuko C13 0.5mm2 230V 10A,screws 6pcs M3 8mm,19" mounting brackets 2pcs
Accessories (ordered separately)	Rotatable mounting brackets, Battery holder
Others	Chassis grounding (M4 thread), recovery switch & restart button

**Specifications are subject to change without notice based on technical recommendations and related product enhancements*

Dimensions (T.10.825)

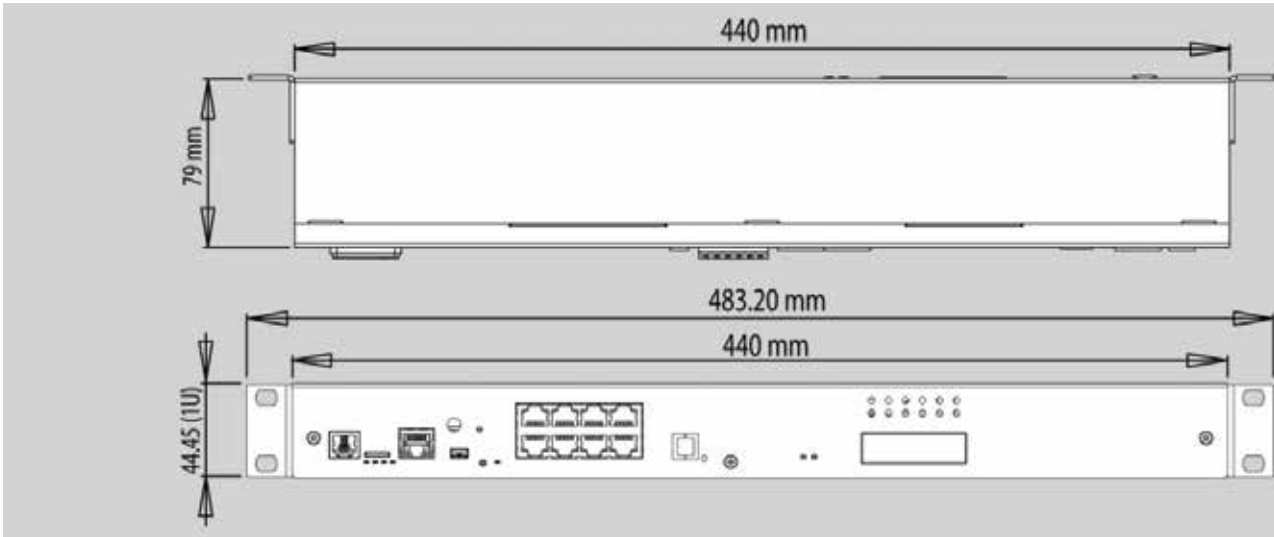

Extensions Order Options (Ordered Separately)

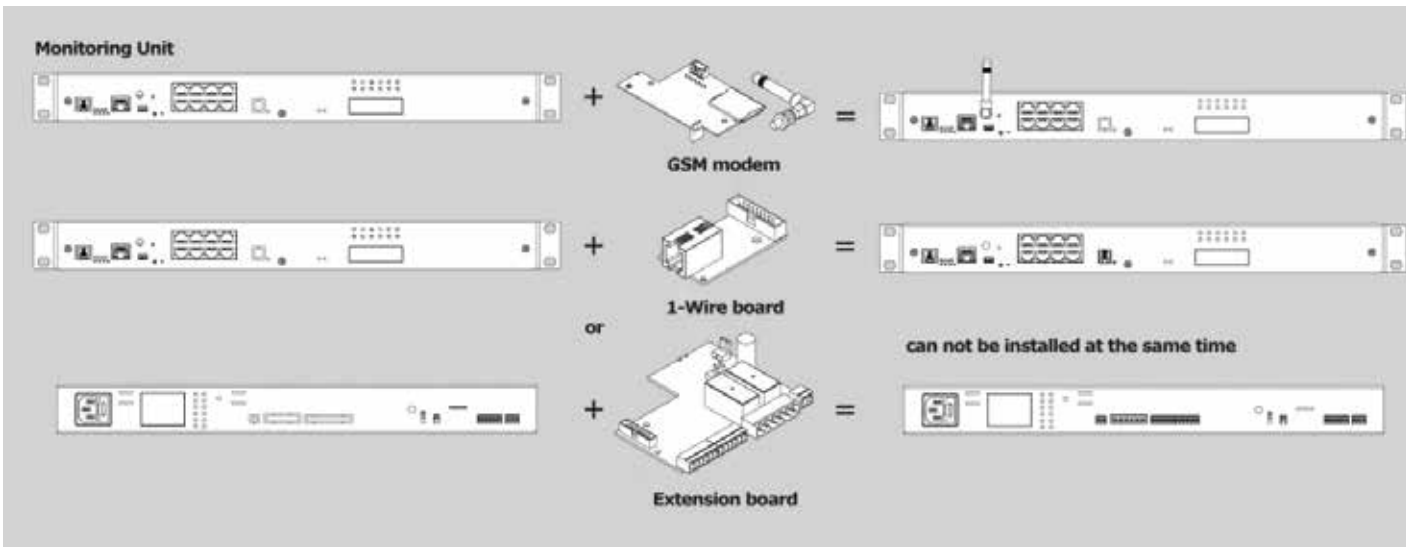

**Specifications are subject to change without notice based on technical recommendations and related product enhancements*

Accessories Order Options (Ordered Separately)

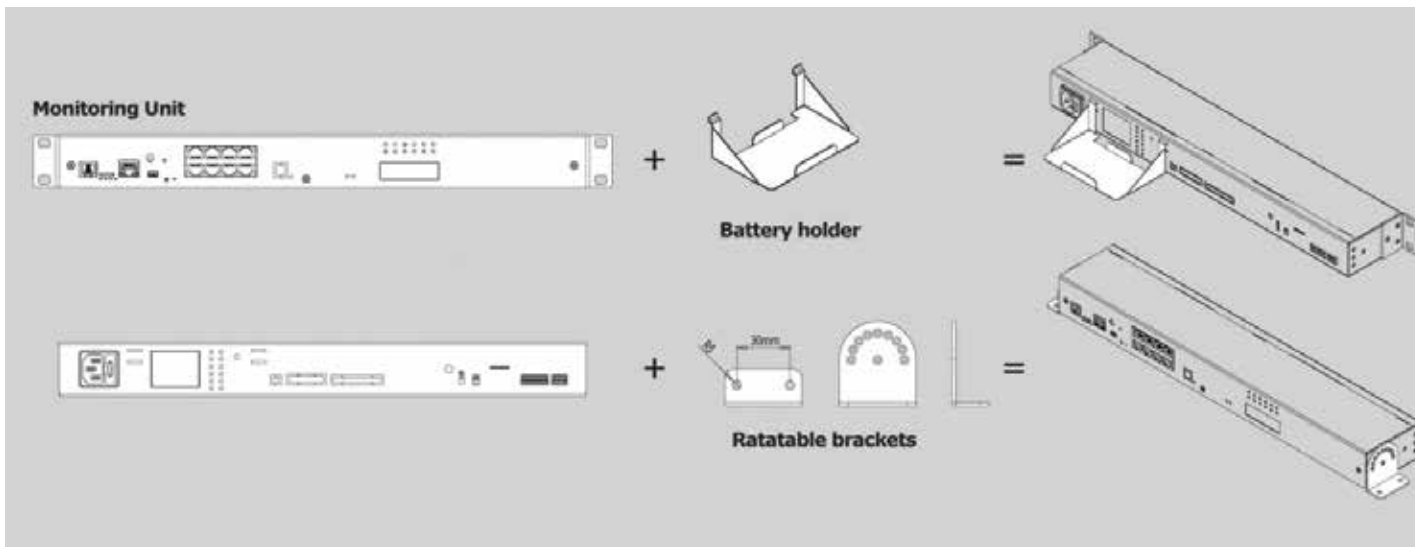

Monitoring System

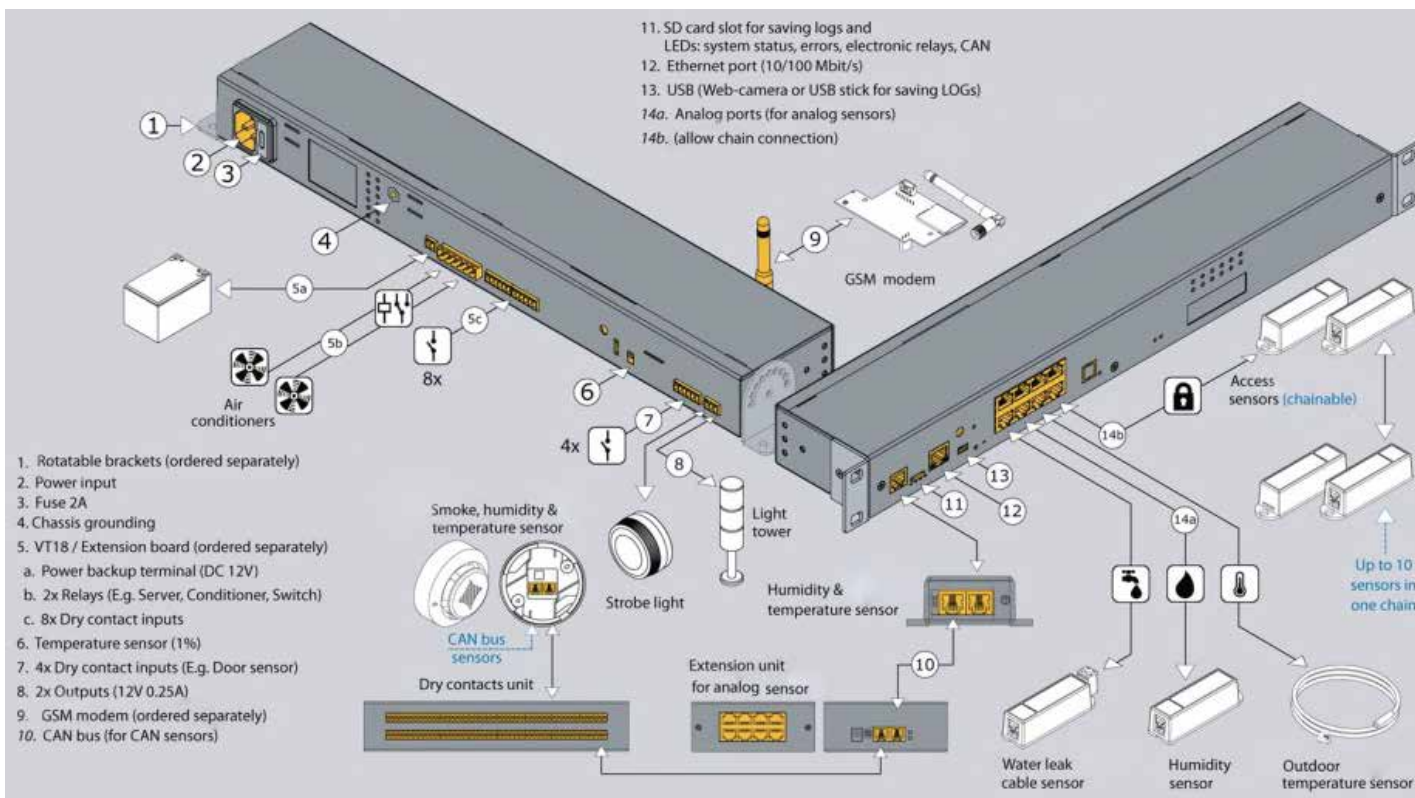

*Specifications are subject to change without notice based on technical recommendations and related product enhancements